

【添付資料⑫】 標準適用範囲:特注可

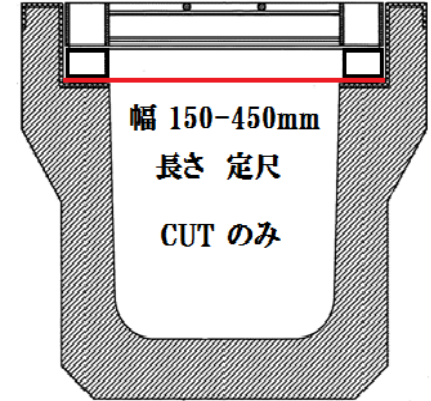

適応できる範囲の確認 雨水枡充填型 : 丸200mm-300mm・角240mm-600mm

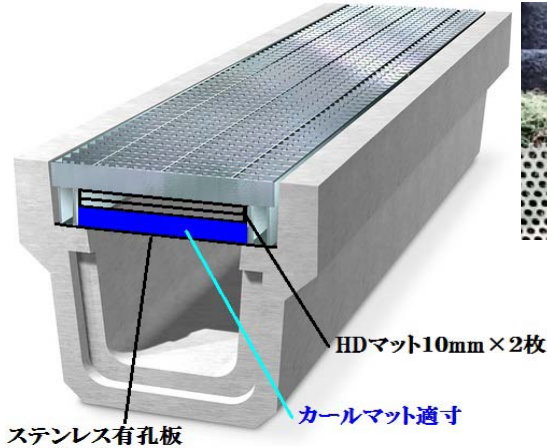
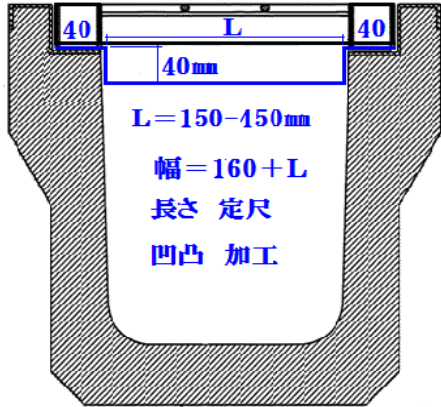

適応できる範囲の確認 U字溝SS型【受け金具凸凹 : CUTのみ共】 150mm-600mm

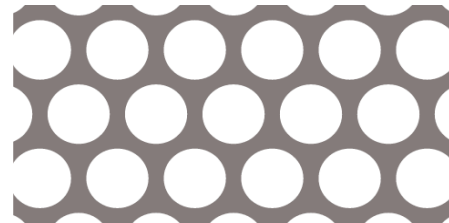

分別マットずれ防止用ステンレス有孔板をグレーチング足又は固定ボルトを利用してタワミが出ない様に固定する。

